

Operating Instructions

HV 150

Hand Knife Grinding Attachment



Operating Instructions

Hand Knife Grinding Attachment HV 150

Manufacturer

KNECHT Maschinenbau GmbH
Witschwender Straße 26
88368 Bergatreute
Germany

Phone +49-7527-928-0
Fax +49-7527-928-32

mail@knecht.eu
www.knecht.eu

Documents for machine operator

Operating Instructions

Date of issue of the operating instructions

January 22, 2024

Copyright

These operating instructions as well as the operating documents remain the copyright property of KNECHT Maschinenbau GmbH. They are supplied only to customers and operators of our products and belong to the machine.

Without our express permission, these documents may neither be duplicated nor made accessible to third parties, in particular competitor companies.

Table of Contents

1.	Important notes	7
1.1	Preface to the operating instructions	7
1.2	Warnings and symbols in the operating instructions	7
1.3	Figure and item numbers in the operating instructions	8
2.	Safety	9
2.1	Basic safety instructions	9
2.1.1	Observe notes in the operating instructions	9
2.1.2	Obligation on the part of the operator	9
2.1.3	Obligation on the part of the personnel	9
2.1.4	Hazards involved in handling the sharpening machine	9
2.1.5	Malfunctions	10
2.2	Intended use	10
2.3	Warranty and liability	10
2.4	Safety regulations	11
2.4.1	Organizational measures	11
2.4.2	Protective equipment	11
2.4.3	Informal safety measures	11
2.4.4	Selection and qualification of personnel	11
2.4.5	Machine control system	12
2.4.6	Safety measures in normal operation	12
2.4.7	Hazards due to electrical power sources	12
2.4.8	Particular hazard areas	12
2.4.9	Servicing (maintenance, repair) and fault rectification	12
2.4.10	Structural alterations to the grinding attachment	13
2.4.11	Cleaning the grinding attachment	13
2.4.12	Lubricants/oils and greases	13
2.4.13	Relocation of the sharpening machine with grinding attachments	13
3.	Description	14
3.1	Intended use	14
3.2	Technical specifications	14
3.3	Functional description	14
3.4	Description of assemblies	15
4.	Transport	16
4.1	Transport aids	16
4.2	Transport damage	16
4.3	Transport to another installation site	16

Table of Contents

5.	Installation	17
5.1	Selection of qualified personnel	17
5.2	Installation site	17
5.3	Settings	17
5.4	Initial start-up of the grinding attachment	17
6.	Commissioning	18
6.1	Fitting the HV 150 Hand Knife Grinding Attachment	18
6.1.1	Fitting CBN grinding wheels	18
6.1.2	Fitting the HV 150 Hand Knife Grinding Attachment	22
6.1.3	Aligning the HV 150 Hand Knife Grinding Attachment	23
7.	Operation	25
7.1	Sharpening hand knives	25
7.1.1	Switching on the sharpening machine	25
7.1.2	Coolant regulation	25
7.1.3	Sharpening the hand knife	26
7.1.4	Deburring and polishing the hand knife	27
7.2	Changing CBN grinding wheels	28
8.	Care and maintenance	30
8.1	Cleaning	30
8.1.1	Cleaning agent and lubricant table	30
8.2	Maintenance plan (one-shift operation)	30
9.	Disassembly and disposal	31
9.1	Disassembly	31
9.2	Disposal	31
10.	Service, spare parts and accessories	32
10.1	Postal address	32
10.2	Service	32
10.3	Wear and spare parts	32
10.4	Accessories	33
10.4.1	Abrasives used	33

Table of Contents

11.	Appendix	34
11.1	EU Declaration of Conformity	34

1. Important notes

1.1 Preface to the operating instructions

These operating instructions are intended to make it easy to learn how to use the HV 150 Hand Knife Grinding Attachment, hereafter referred to as grinding attachment and to properly utilize its features.

These operating instructions contain important notes on how to operate the grinding attachment safely, properly and efficiently. Observing these instructions helps to avoid hazards, reduce repair costs and downtimes and to increase the reliability and service life of the grinding attachment.

The operating instructions must always be stored in the location that the grinding attachment is used.

The operating instructions must be read and applied by every person tasked with working with the grinding attachment, e.g.:

- transport, installation, commissioning
- operation, including error rectification during operation, as well as
- servicing (maintenance, repair).

Recognized technical standards for safe and professional work must be observed in addition to these operating instructions and the binding accident prevention regulations applicable in the country of use and at the place of use.

1.2 Warnings and symbols in the operating instructions

The operating instructions use the following symbols/designations that must be followed:



The hazard triangle with the signal word “CAUTION” serves as a work safety notice for all work for which there is a risk of personal injury or death.

In these cases, work should be done with special attention and care.



“ATTENTION” is written in places where special attention must be paid to prevent damage or destruction of the grinding machine or its surroundings.



“NOTICE” refers to user tips and especially useful informations.

1. Important notes

1.3 Figure and item numbers in the operating instructions

If the text makes a reference to a machine component depicted in a figure, the figure and position number will be given in brackets.

Example: (6-9/1) means picture number 6-9, position 1.

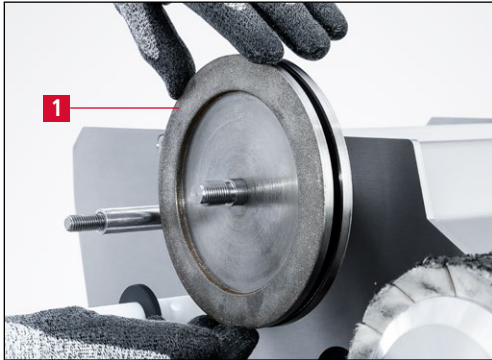

Move the second CBN grinding wheel (6-9/1) onto the grinding spindle up to the intermediate flange (6-8/1).

Figure 6-9 Mounting the second CBN grinding wheel

2. Safety

2.1 Basic safety instructions

2.1.1 Observe notes in the operating instructions

The basic prerequisite for the safe handling and uninterrupted operation of this grinding attachment is knowledge of the basic safety instructions and regulations.

- These operating instructions contain important notes on how to operate the grinding attachment safely.
- All persons carrying out work on the grinding attachment must follow these operating instructions, in particular the safety notices.
- In addition, the rules and regulations regarding accident prevention at the place of use are to be observed.

2.1.2 Obligation on the part of the operator

The operator is obliged to allow only those persons to work on the grinding attachment, who

- are familiar with the occupational safety and accident prevention regulations and have received instruction in handling the grinding attachment,
- have read and understood the operating instructions, in particular the section entitled "Safety" and the warning notes and have provided signed confirmation of this.

The safety-awareness of the personnel at work will be monitored at regular intervals.

2.1.3 Obligation on the part of the personnel

All personnel working on the grinding attachment shall be obliged, before starting work, to

- observe basic occupational safety and accident prevention regulations,
- read the operating instructions, particularly the section entitled "Safety" and the warning notes and provide signed confirmation that they have understood them.

2.1.4 Hazards involved in handling the sharpening machine

The grinding attachment has been built to the latest technological standards and the recognized rules of technical safety. In spite of this, its use poses inherent risks which could result in bodily harm or even death of the user or third persons, or damage to the sharpening machine or other property.

The grinding attachment may be used only

- for its intended purpose
- in a safe and secure condition.

Malfunctions that may impair safety are to be eliminated immediately.

2. Safety

2.1.5 Malfunctions

If safety-relevant malfunctions occur with the grinding attachment, or if the processing behavior indicates that such malfunctions may have occurred, the sharpening machine must be stopped immediately and until such time as the malfunction has been found and eliminated.

Allow only authorized trained personnel to eliminate the malfunctions.

2.2 Intended use

The grinding attachment is exclusively suitable for sharpening hand knives.

Any other use or use beyond this is not considered as intended. KNECHT Maschinenbau GmbH is not liable for any damage resulting from this. The risk is borne solely by the user.

Intended use also includes observing all instructions in the operating manual.

ATTENTION

The grinding machine and the HV 150 Hand Knife Grinding Attachment are not being used as intended if, for example:

- **Devices are not properly fastened.**
- **Knives are sharpened / polished against the cutting edge on the wet-grinding belt and the polishing disk.**

2.3 Warranty and liability

Warranty and liability claims in case of personal injury or property damage are excluded if such damage is attributable to one or more of the following causes:

- improper use of the grinding attachment,
- improper transport, commissioning, operation and maintenance of the grinding attachment,
- operating the grinding attachment with defective safety devices, or using improperly attached or malfunctioning safety and protective equipment,
- failure to observe the instructions with regard to transportation, commissioning, operation, maintenance and repair of the grinding attachment,
- unauthorized structural alterations to the grinding attachment,
- unauthorized modification, e.g. of the drive conditions (output and speed),
- failure to monitor machine parts that are subject to wear, and
- use of unapproved replacement and wear parts.

2. Safety

Use only original replacement and wear parts. If externally purchased parts are used, it is not guaranteed that they have been designed and manufactured to meet the requirements in terms of stress and safety.

2.4 Safety regulations

2.4.1 Organizational measures

Inspect all available safety devices regularly.

Observe prescribed intervals for recurring maintenance work or as specified in the operating instructions!

2.4.2 Protective equipment

Before every commissioning of the grinding attachment, ensure that all protective equipment is properly mounted and in functional condition.

Protective equipment may be removed only after the sharpening machine has stopped and has been secured against accidental restart.

When attaching spare parts, the protective equipment must be attached by the operator as stipulated.

2.4.3 Informal safety measures

The operating instructions must be permanently available at the place of use of the grinding attachment. In addition to the operating instructions, the generally applicable as well as locally relevant accident prevention regulations must also be made available and observed.

All safety alert symbols and hazard warnings on the sharpening machine must be complete and clearly legible.

2.4.4 Selection and qualification of personnel

Only trained and instructed personnel may work on the grinding attachment. Observe the legally permitted minimum age!

The responsibilities of personnel with respect to commissioning, operation, maintenance and repair must be clearly specified.

Personnel still undergoing training or instruction may only work on the grinding attachment under the permanent supervision of an experienced person!

2. Safety

2.4.5 Machine control system

Only trained and instructed personnel are permitted to switch on and operate the machine.

2.4.6 Safety measures in normal operation

Do not operate the machine in any unsafe manner. Only operate the grinding attachment if all the safety devices are installed and fully functional.

At least once per shift (or per day), check the grinding attachment for externally visible damage and proper functioning of the safety devices.

Immediately report any changes present (including those of the operating behavior) to the responsible office or person. If necessary, immediately shut down the sharpening machine and secure it against restart.

Before you switch on the sharpening machine, ensure that no one can be injured by the start-up of the machine.

In the event of a malfunction, immediately stop the sharpening machine and secure it against restart. Rectify malfunctions immediately.

2.4.7 Hazards due to electrical power sources

Work on electrical systems or operating materials may only be performed by a qualified electrician, in accordance with electrical regulations.

Defects, such as damaged cables, cable connections, etc. must be immediately rectified by an authorized specialist.

2.4.8 Particular hazard areas

In the area of the grinding wheels there is a hazard of pinching and of drawing in e.g. clothing, fingers and hair. Suitable personal protective equipment must be worn.

2.4.9 Servicing (maintenance, repair) and fault rectification

Maintenance work is to be carried out on schedule by trained personnel. Inform operating personnel before beginning repair work. Designate a supervisor responsible for this.

For all service work, the sharpening machine is to be disconnected from the current supply and secured against accidental restart.

Remove power plug. Secure repair area as necessary.

After completing maintenance work and rectifying any faults, install all safety devices and verify that they are fully functional.

2. Safety

2.4.10 Structural alterations to the grinding attachment

Do not make any changes, additions or conversions to the grinding attachment without the approval of the manufacturer. This also applies to the installation and setup of safety devices.

Any conversion work requires the written permission from KNECHT Maschinenbau GmbH.

Immediately replace machine parts that are not in perfect condition.

Use only original replacement and wear parts. If externally purchased parts are used, it is not guaranteed that they have been designed and manufactured to meet the requirements in terms of stress and safety.

2.4.11 Cleaning the grinding attachment

Properly handle any cleaning agents and materials used and dispose of them in an environmentally-friendly manner.

Dispose of the wear parts and replacement parts in a safe and environmentally-friendly manner.

2.4.12 Lubricants/oils and greases

When using oils and greases, follow the safety regulations applicable to the product. Comply with the special regulations for the food areas.

2.4.13 Relocation of the sharpening machine with grinding attachments

Disconnect the sharpening machine from any external power supply, even in the event of a minor change of location. Before restarting the sharpening machine, connect it properly to the power supply.

For loading work, use only lifting equipment and load-bearing devices with sufficient lifting capacity. Appoint a qualified instructor for the lifting operation.

No persons other than those designated for this work may be present in the loading and installation area.

Only use a suitable transport vehicle with sufficient load-bearing capacity. Secure the load reliably. See also the operating instructions for the USK160S Universal Wet-Sharpener Machine (Chapter 4. Transport).

When restarting the machine, proceed only in accordance with the operating instructions.

3. Description

3.1 Intended use

The HV 150 Hand Knife Grinding Attachment is used to sharpen hand knives. The device is used on the KNECHT sharpening machines of the USK 160S model series.

3.2 Technical specifications

Height _____ approx. 130 mm

Width _____ approx. 90 mm

Depth _____ approx. 360 mm

Weight _____ approx. 2,5 kg

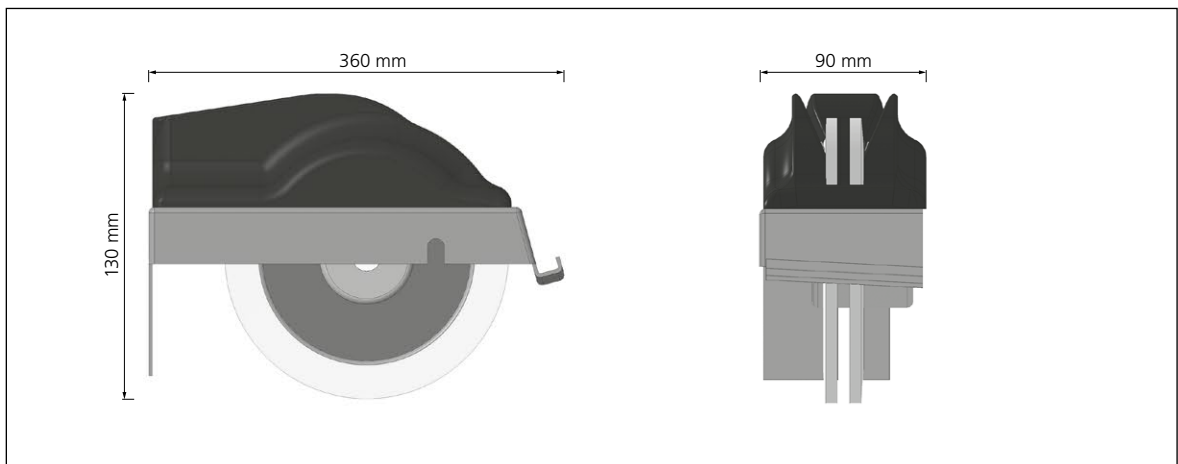

Figure 3-1 HV150 side view and front view (dimensions in mm)

3.3 Functional description

The HV 150 Hand Knife Grinding Attachment is used to sharpen hand knives from 50 to 550 mm in length.

The knife guides ensure that the hand knives are always ground with the correct cutting edge angle. Additional integrated magnets support the guidance of the knife and make sharpening very simple.

NOTE

For hand knives longer than 300 mm, the splash guard (3-2/1) must be removed.

3. Description

3.4 Description of assemblies

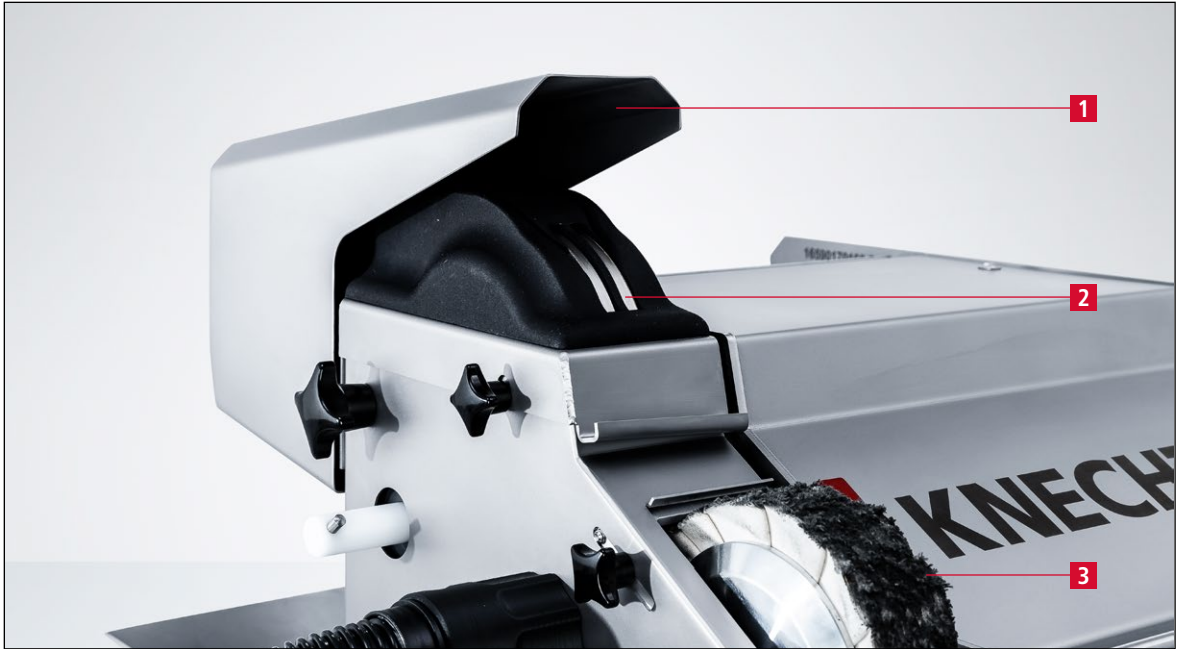

Figure 3-2 HV 150 Hand Knife Grinding Attachment

- 1 Splash guard
- 2 Grinding wheels
- 3 Polishing disk

4. Transport



When transporting, observe the local applicable safety and accident prevention regulations.

4.1 Transport aids

For transporting of the grinding attachment, only use adequately dimensioned transport aids.

4.2 Transport damage

If damage is detected after unloading, during acceptance of the delivery, immediately inform KNECHT Maschinenbau GmbH and the forwarding agent. If necessary, an independent expert must be called in immediately.

Remove packaging and fastening straps. Dispose of packaging in an environmentally-friendly manner.

4.3 Transport to another installation site

For transport to another installation site, ensure that the space requirements are fulfilled (see Chapter 3.2).

The grinding attachment must be adequately secured during transport.

5. Installation

5.1 Selection of qualified personnel



We recommend having installation work on the grinding attachment carried out by the trained KNECHT personnel.

We are not liable for any damage resulting from improper installation.

5.2 Installation site

When determining the installation site, bear in mind the space required for installation as well as maintenance and repair work on the grinding attachment (see Chapter 3.2).

5.3 Settings

KNECHT Maschinenbau GmbH will configure the various components before delivery.

ATTENTION

Unauthorized alterations to the preset values are not permitted and can damage the grinding attachment.

5.4 Initial start-up of the grinding attachment

Completely install and inspect the protective equipment before commissioning.

The HV 150 grinding attachment may only be used with the KNECHT grinding machines of the USK 160S model series.



Have all protective equipment checked for proper functioning by authorized trained personnel before commissioning the machine.

6. Commissioning



All work must be performed by authorized trained personnel.
Observe the locally applicable safety and accident prevention regulations.
There is a risk that hands, hair and clothing may be pulled in while the sharpening machine is switched on.
Serious injury may result. Wear personal protective equipment.

6.1 Fitting the HV 150 Hand Knife Grinding Attachment

6.1.1 Fitting CBN grinding wheels



Figure 6-1 Removing the splash guard

Two CBN grinding wheels are mounted for sharpening hand knives with the HV150.

First remove the splash guard (6-1/1).

Open the knurled screw (6-1/2) and remove the splash guard (6-1/1) to the rear.

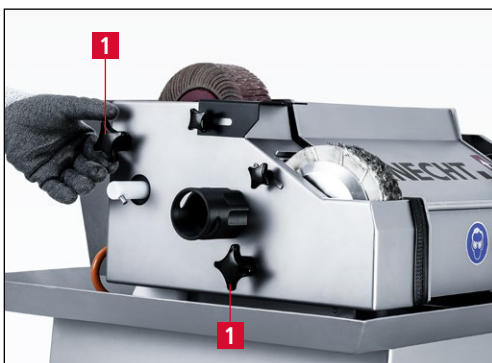

Figure 6-2 Removing the protection hood

Loosen the two star handles (6-2/1) on the left-hand side of the machine and remove the protection hood.

Then remove the finned-grinding wheel.

6. Commissioning

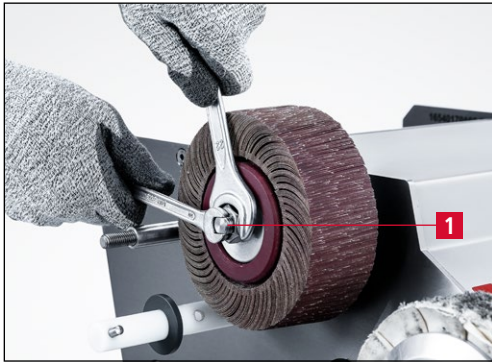

Figure 6-3 Loosening the finned-grinding wheel

To do this, open the hexagon nut (6-3/1) **counter-clockwise** using an open-end wrench AF 22 mm.

Secure the shaft with the 10 mm open-end wrench.



Figure 6-4 Removing the finned-grinding wheel

Remove the finned-grinding wheel (6-4/1).

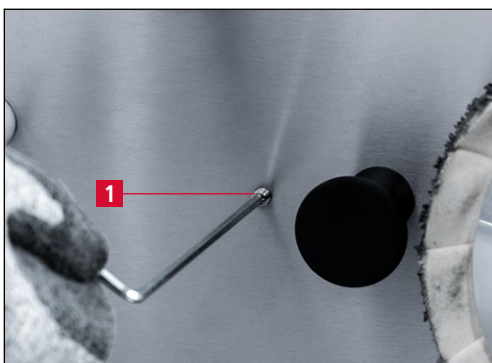

Figure 6-5 Unscrewing the setscrew

Unscrew the setscrew (6-5/1) on the left side wall using a hexagon screwdriver AF 3 mm.

6. Commissioning

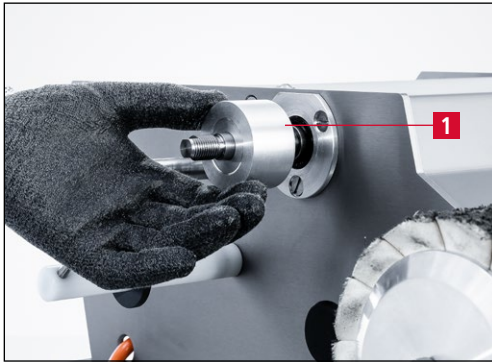

Figure 6-6 Placing the 30 mm clamping flange

Place the 30 mm thick clamping flange (6-6/1) onto the grinding spindle as far as it will go.



Figure 6-7 Fitting the CBN grinding wheel

Fit the first CBN grinding wheel (6-7/1) up to the 30 mm clamping flange.

NOTE

The recess on the grinding wheel (6-7/1) must point towards the machine.

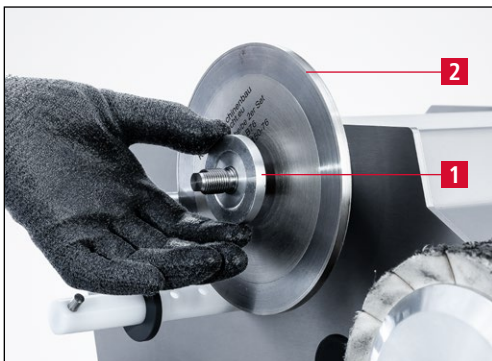

Figure 6-8 Placing the 6.5 mm intermediate flange

Place the 6.5 mm thick intermediate flange (6-8/1) up to the first grinding wheel (6-8/2) on the grinding spindle.

6. Commissioning

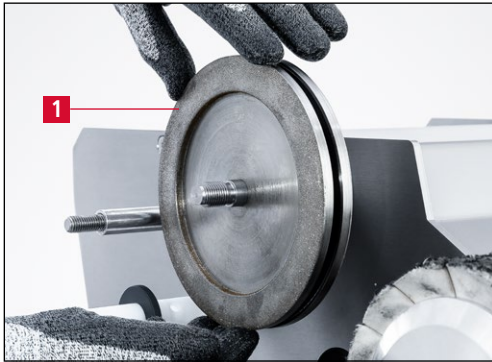

Figure 6-9 Fitting the second CBN grinding wheel

NOTE

Fit the second CBN grinding wheel (6-9/1) onto the grinding spindle up to the intermediate flange (6-8/1).

The recess on the grinding wheel (6-9/1) must face outwards.

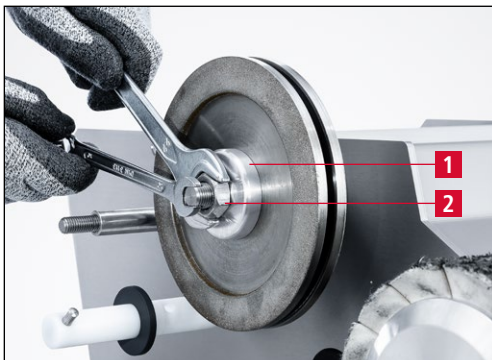

Figure 6-10 Tightening the CBN grinding wheel and the clamping flange

Fit the 10 mm thick clamping flange (6-10/1) and turn the nut (6-10/2) onto the thread by hand.

Then tighten the nut (6-10/2) with the two open-end wrenches (AF 10 mm and AF 22 mm).

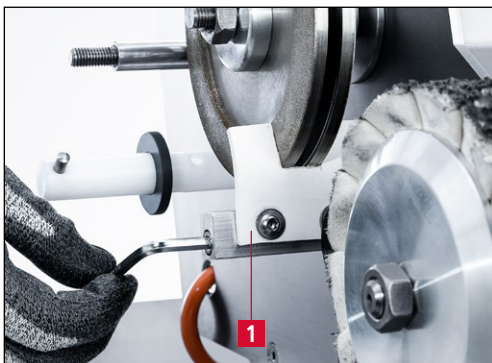

Figure 6-11 Fitting the wiper

If not already present, fit the wiper (6-11/1) using the AF 4 mm hexagon screwdriver and align with the grinding wheels.

6. Commissioning

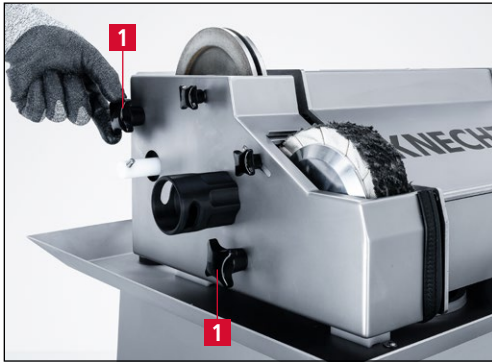

Figure 6-12 Fitting the protection hood

Refit the protection hood and tighten moderately using the two star handles (6-12/1).

6.1.2 Fitting the HV 150 Hand Knife Grinding Attachment



Figure 6-13 Attaching the HV 150

Attach the HV 150 Hand Knife Grinding Attachment to the protection hood from above.

The two grooves (6-13/1) must rest on the setscrews.

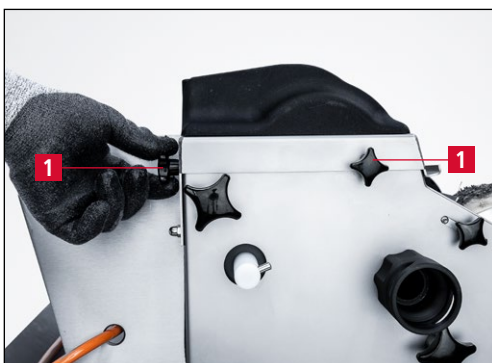

Figure 6-14 Moderately tightening the HV 150

Use the two star handles (6-14/1) to moderately tighten the HV 150 on the left and rear side.

6. Commissioning

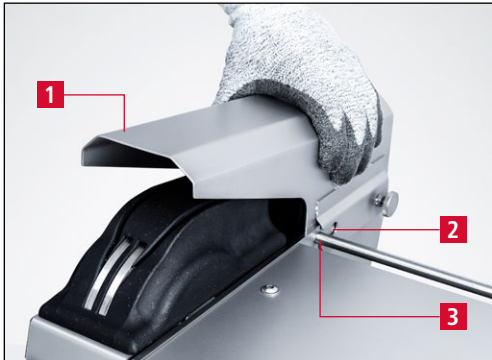

Figure 6-15 Fitting the splash guard

Slide on the splash guard (6-15/1) from the rear.

Ensure that the slot (6-15/2) engages completely into the handle bar (6-15/3).

6.1.3 Aligning the HV 150 Hand Knife Grinding Attachment



Figure 6-16 Removing the splash guard

If the grinding wheels are rubbing against the grinding attachment, the black knife guide hood must be realigned.

To do this, remove the splash guard (6-16/1) to the rear.



Figure 6-17 Removing the HV 150

Then loosen and remove the grinding attachment using the two star handles (6-17/1).

6. Commissioning

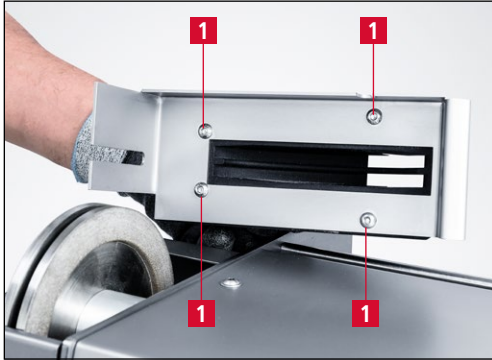

Figure 6-18 Aligning the knife guide hood

Slightly loosen the four M6 screws (6-18/1) on the underside of the grinding attachment using a hexagon screwdriver AF4 mm and move the hood until the grinding wheels no longer rub.

Then tighten the four M6 screws (6-18/1) again and mount the hand knife grinding attachment in reverse order.

7. Operation



There is a risk that hands, hair and clothing may be pulled in while the sharpening machine is switched on.

Serious injury may result!

Grinding create abrasive particles that can enter the eyes. Wear safety glasses.

ATTENTION

Before operating the sharpening machine, check that the CBN grinding wheels are running freely. The grinding wheels must not rub against the hand knife grinding attachment.

If necessary, realign the grinding attachment (see Chapter 6.1.3).

7.1 Sharpening hand knives

7.1.1 Switching on the sharpening machine



Figure 7-1 Switching on the sharpening machine

Switch on the sharpening machine. To do so, turn the "ON/OFF" switch (7-1/1) of the USK 160 S to the "I" position.

7.1.2 Coolant regulation



Figure 7-2 Adjusting the water nozzle

The coolant is dosed by swiveling the water nozzle (7-2/1).

Turning the water nozzle (7-2/1) clockwise = less coolant

Turning the water nozzle (7-2/1) counterclockwise = more coolant

7. Operation

NOTE

The CBN grinding wheels should only be wetted with coolant.

7.1.3 Sharpening the hand knife

NOTE

Knives must be cleaned before sharpening.



Figure 7-3 Sharpening the hand knife

For sharpening, place the hand knife as close as possible to the handle in the knife guide (7-3/1). The knife guide is magnetic and supports the exact guidance.

Position the blade horizontally and pull it slowly towards the tip along the grinding wheel with even pressure.

In the area of the knife tip, move the handle upwards according to the shape of the knife.



Figure 7-4 Sharpening the hand knife

Repeat the process alternately on the right and left side until a fine burr is produced.

NOTE

Always start the sharpening process at the knife handle.

7. Operation

7.1.4 Deburring and polishing the hand knife



Figure 7-5 Deburring and polishing the hand knife

Then deburr and polish the hand knife on the polishing disk (7-5/1) as described in the USK 160S operating instructions.

After completion the sharpening process, switch off the grinding machine.

To do so, turn the "ON/OFF" switch (7-1/1) to the "0" position.

7. Operation

7.2 Changing CBN grinding wheels



Do not switch on the machine with the protection hoods removed!

Serious injuries are possible!



Figure 7-6 Removing the splash guard

To change the CBN grinding wheels, first remove the splash guard (7-6/1).

Open the knurled screw (7-6/2) and remove the splash guard (7-6/1) to the rear.



Figure 7-7 Removing the grinding attachment

Use the two star handles (7-7/1) on the left and rear side to loosen the HV 150 and remove it upwards.

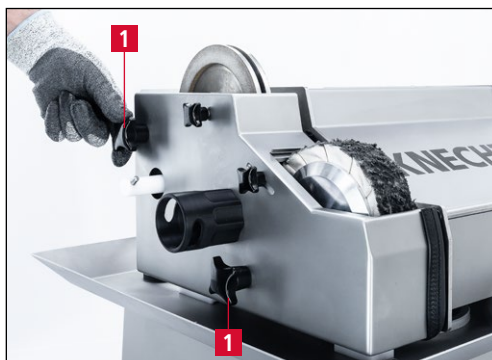

Figure 7-8 Removing the protection hood

Loosen the two star handles (7-8/1) on the left side of the machine and remove the protection hood.

Clean the protection hood under running water.

7. Operation

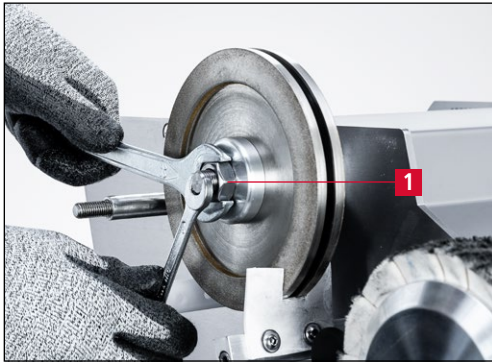

Figure 7-9 Loosening the grinding wheels

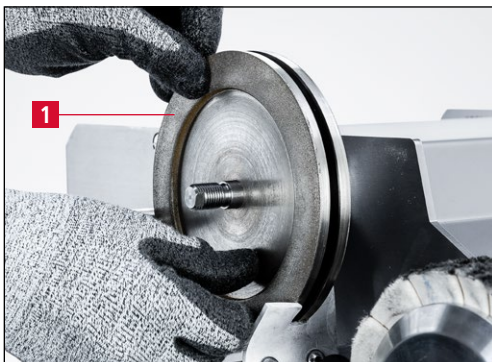

Figure 7-10 Removing the grinding wheels and replacing them with new ones

NOTE

ATTENTION

Then remove the CBN grinding wheels.

To do this open the hexagon nut (7-9/1) **counter-clockwise** using the open-end wrench AF22 mm.

Secure the shaft with the open-end wrench AF 10mm.

Pull the 10 mm thick clamping flange, the used grinding wheels (7-10/1) and the 6.5 mm thick intermediate flange off the grinding spindle and fit new ones in reverse order.

Refit the protection hood. Tighten the star handles (7-8/1) moderately.

Fit the grinding attachment (see Figure 7-7) and tighten with the star handles (7-7/1).

Fit the splash guard (7-6/1).

Perform a function check.

If the grinding wheels rub against the grinding attachment, the knife guide hood must be realigned (see Chapter 6.1.3).

Only original abrasives from KNECHT Maschinenbau GmbH are permitted to be used.

KNECHT Maschinenbau GmbH assumes no responsibility for the use of non-original abrasives.

8. Care and maintenance



For all work on the HV 150 Hand Knife Grinding Attachment, observe the locally applicable safety and accident prevention regulations as well as instructions in the "Safety" and "Important notes" section of the operating instructions.

8.1 Cleaning

The hand knife grinding attachment must be cleaned daily, otherwise the grinding abrasion dries and is difficult to remove.

After cleaning, we recommend the products listed below for the care of the machine (see also Cleaning agent and lubricant table, Chapter 8.1.1).

8.1.1 Cleaning agent and lubricant table

Cleaning / Lubrication work	Interflon	WÜRTH	SHELL	EXXON Mobil
Cleaning and care of machine parts	Dry Clean Stainless Steel	Stainless steel care spray	Risella 917	Marcol 82
Lubricate threads and sliding surfaces	Fin Grease	Multi-purpose grease	Gadus S2	Ronex MP

8.2 Maintenance plan (one-shift operation)

Interval	Assembly	Maintenance task
Daily	All machine surfaces	Clean with soft cloth and care spray.
Weekly	Threads of the star handles	Lubricate with multi-purpose grease
Annually		Contact the service department of KNECHT Maschinenbau GmbH.

9. Disassembly and disposal

9.1 Disassembly

All operating materials must be disposed of properly.

Secure moving parts against slippage.

Disassembly must be conducted by a qualified specialist.

9.2 Disposal

After the machine has reached the end of its service life, it must be disposed of by a qualified specialist. In exceptional situations and after consultation with KNECHT Maschinenbau GmbH, the machine may be returned.

Operating materials (e.g. grinding wheels etc.) must also be disposed of correctly.

10. Service, spare parts and accessories

10.1 Postal address

KNECHT Maschinenbau GmbH
Witschwender Straße 26
88368 Bergatreute
Germany

Phone +49-7527-928-0
Fax +49-7527-928-32

mail@knecht.eu
www.knecht.eu

10.2 Service

Service line:

For address, see postal address

service@knecht.eu

10.3 Wear and spare parts

If you need spare parts, please use the spare parts list provided with the machine. Please place your order using the format described below.

When ordering, please always provide: (example)

Machine typ	(HV 150)
Designation of individual part	(wiper for CBN only)
Position number	(2)
Drawing number (article number)	(1000060-17676)
Quantity	(1 pc)

We are always happy to answer any questions.

10. Service, spare parts and accessories

10.4 Accessories

10.4.1 Abrasives used

Designation	Dimensions	Article number	Note
CBN grinding wheel set of 2	d.150x7xd.15H7 B64	412F-83-0150-64	included in scope of delivery

ATTENTION

Only original abrasives, wear and spare parts from KNECHT Maschinenbau GmbH are permitted to be used.

KNECHT Maschinenbau GmbH assumes no responsibility for the use of non-original parts.

If you require abrasives or other accessories, please contact our sales staff and distributors, or KNECHT Maschinenbau GmbH directly.

Thank you for your confidence!

11. Appendix

11.1 EU Declaration of Conformity

in accordance with EU Directive 2006/42/EU

- Machinery 2006/42/EU
- Electromagnetic Compatibility 2014/30/EU

We hereby declare that the machine designated as follows, due to its construction and design, as well as the version we placed on the market, complies with the relevant fundamental safety and health requirements of the applicable EU Directive.

In case of a modification of the machine not agreed with us, this declaration loses its validity.

Machine designation: Typbezeichnung:	Hand Knife Grinding Attachment HV 150
Applicable harmonized standards, in particular:	DIN EN 12100-1 DIN EN 12100-2 DIN EN 60204-1 ISO 13857 DIN EN 349
Responsible for documentation:	Peter Heine (B. Eng. Mechanical Engineering BA) Phone +49-7527-928-15 p.heine@knecht.eu
Manufacturer:	KNECHT Maschinenbau GmbH Witschwender Straße 26 88368 Bergatreute Germany

A complete technical documentation is available. The operating instructions document for the machine is available in its original version and in the native language of the user.

The validity of the declaration expires in the event of changes to the legal requirements.

Bergatreute, January 22, 2024

KNECHT Maschinenbau GmbH

Markus Knecht
CEO

KNECHT Maschinenbau GmbH

Witschwender Straße 26 · 88368 Bergatreute · Germany · T +49-7527-928-0 · F +49-7527-928-32
mail@knecht.eu · www.knecht.eu